

# MODEL XB110HL1 VENTILATION FAN WITH LIGHT

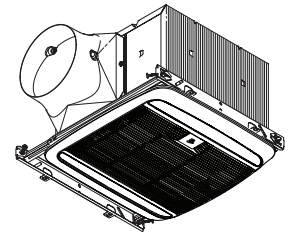

### FEATURES

#### ULTRASMART™ DC Motor and Control Technology

- DC motor for efficiency well beyond ENERGY STAR® requirements.
- Can be used to comply with ASHRAE 62.2, LEED, ENERGY STAR® for Homes and CA Title 24.
- Powerful operation maintained over a wide range of real-world installations (CFM ratings maintained through at least 0.25" static pressure).
- Rated for Continuous Operation.

#### ULTRASILENT™ Sound Technology

- HVI certified, best-achievable <0.3 Sone level provides nearly silent operation for a relaxing environment.
- State-of-the-art blower and duct outlet design smooths airflow.
- High tech DC motor designed for nearly silent operation.

#### ULTRALUCENT™ Lighting Technology

- LIGHTING / GRILLE:
- Highly efficient, 18 Watt, integrated LED, dimmable
  - LED lasts up to 25,000 hours
  - Unique, low profile design for wide light pattern
  - Even lens diffusion eliminates hotspots

#### TO OPERATE FAN AND LIGHT:

- Use only an ON/OFF or timer switch to operate the fan.
- Use only an ON/OFF switch, timer switch or relay-switch to operate the LED light.
- The LED light can be used with some dimmable switches (see below).
- Both the fan and LED light can be put on one switch.

#### DIMMING CONTROLS :

- May not be compatible with all dimmer controls
- Each application is unique and various factors such as load, common neutrals or other electrical products on the circuit can, in certain instances, cause variance in system performance.
- Dimmer model numbers vary slightly depending on color, packaging type, etc. such that variations of Model numbers may be suitable. Consult dimming system manufacturer for additional support in operation

\* For a list of compatible controls, see broan.com.

#### ULTRAQUICK™ Installation Technology

- Unique telescoping mounting frame fits through retrofit drywall opening to allow easy installation from the room side. No attic access needed!
- Captive screws allow for easy new construction installation.
- Mounting frame positioning tabs provide easy vertical positioning for new construction.
- Easy to insert and remove snap-in housing. No screws required!
- Easy to insert and remove snap-in blower.

- Inside or outside duct connector and knockout plate mounting provides flexibility for new construction or retrofit.

#### ULTRASENSE™ Humidity Sensing Technology

- Detects humidity at the ceiling where it is greatest, which minimizes reaction time.
- Automatically turns fan on when either of these conditions is detected:
  - Rapid to moderate humidity increase;
  - Humidity above set point (50%-80% RH).
- Humidity level is set with easily accessible user adjustment.
- Can be used to comply with CALGreen standards.
- Two wire manual operation for odor control - Turns fan ON when power line through wall switch is cycled ON, OFF and back ON.
- After humidity has stabilized and is below set point or after turned on through power line cycling, fan remains on until user adjustable (5 to 60 minutes) time delay set point is reached.

U.L. Listed for use over bathtubs and showers when connected to a GFCI protected branch circuit (ceiling mount only).

U.L. Listed for use in insulated ceilings (Type IC).

Use only ON/OFF switch, mechanical timer or relay-switched control.  
3-year warranty.

### DIMENSIONS (Inches)



JA8-2019

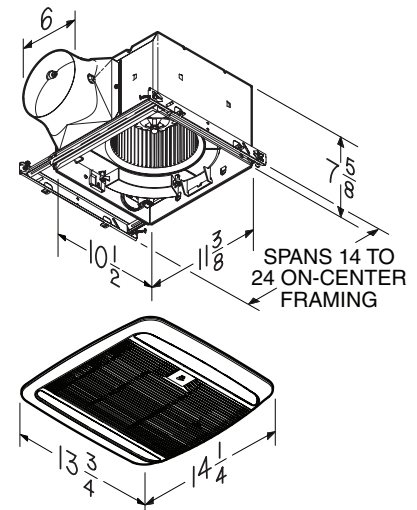

Broan Hartford, Wisconsin www.broan.com 800-558-1711

REFERENCE	QTY.	REMARKS	Project
			Location
			Architect
			Engineer
			Contractor
			Submitted by
			Date



# PERFORMANCE SPECIFICATIONS

## MODEL XB110HL1 VENTILATION FAN WITH LIGHT

### HVI PERFORMANCE

6" Duct				
0.1 Ps - Static Pressure (inH2O)				0.25 Ps
Airflow (CFM)	Sound (Sones)	Power (Watts)	Efficacy (CFM/Watt)	Airflow (CFM)
110	< 0.3	9.3	11.8	110



HVI-2100 CERTIFIED RATINGS comply with new testing technologies and procedures prescribed by the Home Ventilating Institute, for off-the-shelf products, as they are available to consumers. Product performance is rated at 0.1 in. static pressure, based on tests conducted in a state-of-the-art test laboratory. Sones are a measure of humanly-perceived loudness, based on laboratory measurements.

### ELECTRICAL & WEIGHT

Volts	Hz	Amps*	Shipping Weight (lbs.)
120	60	0.5	13.8

\* Total connected load



XB110HL1 - 6" Duct

