



THE B120DHV

DELIVERS DEHUMIDIFIED VENTILATION AND FEATURES A HORIZONTAL CONFIGURATION TO FIT ANY ATTIC, BASEMENT OR CRAWL SPACE INSTALLATION.

PERFORMANCE

| | |
|-----------------------|---|
| Water Removal | 121 Pints / 15.125 Gallons |
| Efficiency | 6.1 Pints/kWh |
| Energy Factor | 2.95 L/kWh |
| Blower | 350 CFM @ 0.0" WG 285 CFM @ 0.2" WG 210 CFM @ 0.4" WG |
| Operating Temperature | 49°F Min., 95°F Max. |
| Sizing | Up to 3,000 Sq. Ft. / 30,000 Cu. Ft. |

ELECTRICAL

| | |
|---------------------|-----------------------------|
| Power | 840 watts @ 80°F and 60% RH |
| Supply Voltage | 115 volt – 1 phase – 60 Hz |
| Current Draw | 7.3 amps |
| Power Cord | 9', 115 VAC, Ground |
| Circuit Requirement | 15 Amps |

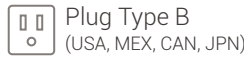

SPECIFICATIONS

| | |
|------------------|---|
| Duct Connections | 6" Round Inlet, 10" Round Inlet, 10" Round Outlet |
| Drain Connection | 3/4" Threaded Female NPT |
| Refrigerant | R410A, 1 lb. 10 oz. |
| Unit Dimensions | 14.375"W x 21"H x 32.1875"D |
| Unit Weight | 91 lbs. |

SHIPPING

| | |
|---------------------|------------------------|
| Shipping Dimensions | 18.5"W x 23.5"H x 40"D |
| Shipping Weight | 101 lbs. |
| Pallet Quantity | 4 per pallet |
| Shipping Options | LTL |

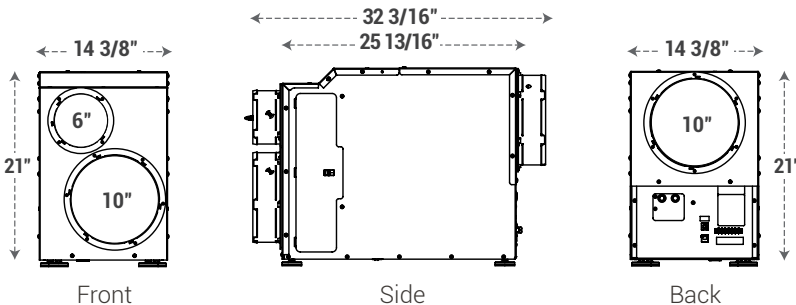

FEATURES

- + Features a horizontal configuration with optional vertical discharge
- + Designed for quiet operation
- + Engineered for low temperature operation providing comfort year round
- + Use of DEH 3000/R digital control for outdoor air ventilation and humidity control
- + Superior MERV-13 filtration to improve indoor air quality
- + Ducting option for fresh outdoor air ventilation
- + Push button reset for transformer protection

| | |
|---------------|-------|
| Project: | |
| Location: | |
| Qty: | |
| Architect: | |
| Engineer: | |
| Contractor: | |
| Submitted by: | Date: |
| Remarks: | |



FILTRATION



MERV-13 FILTER

- + Designed to trap particles down to 0.3 microns
- + 90% ASHRAE Dust Spot
- + 14" x 17.5" x 1.75"

INSTALLATION



DEH 3000 DIGITAL CONTROL

- + Precise monitoring and control of moisture levels
- + Manages fresh air filtration with optional damper
- + Activates air filtration



HANG KIT

- + One person set up
- + Minimal parts
- + Ideal for tight spaces or spaces prone to flooding and standing water

PART NO. ITEM

DHA4037722 MERV-13 Filter

PART NO. ITEM

DHA4028539 DEH 3000 Digital Control

DHA4028407 DEH 3000R Digital Control
(Includes Remote Sensor)

PART NO. ITEM

DHA4036695 Hang Kit

PARTS

| | | | |
|----------|-----------------|-------------|---------------------|
| S4020924 | Fan Relay | S4034431 | Impeller |
| S4022484 | Comp Relay | S4035235-02 | Fan Capacitor |
| S4022487 | Transformer | S4034033 | Compressor Overload |
| S4029510 | Filter Drier | S4033032-04 | Comp Run Capacitor |
| S4036559 | Circuit Breaker | S4036967 | Defrost Thermostat |
| S4026221 | Leveling Feet | | |



926 West State Street, Hartford, WI 53027

www.Broan-Nutone.com 800-558-1711