

DESCRIPTION

BLOWER:

- Plug-in, permanently lubricated motor - engineered for continuous operation
- Dynamically balanced centrifugal blower wheel for quiet, efficient performance
- Maintains a high percentage of rated CFM in less than ideal installations
- Low RPM for quiet operation

HOUSING:

- Rugged, galvanized steel construction
- 6" round ducting for superior performance
- Polymeric duct connector with tapered sleeve and no metallic clatter
- 7-5/8" height allows for 2" x 8" (nominal) joist installations
- Sturdy, easy, four-point mounting directly to joist
- Includes unique, patented spacer for mounting to engineered "I" joists
- Includes hanger bars to position housing anywhere between 16" to 24"-on-center joists
- Two sets of mounting holes for hanger bars allow flush installation with bottom or top of drywall
- Can be mounted in ceilings up to 12/12 pitch

GRILLE:

- Polymeric construction
- Innovative design - the result of extensive research with designers and consumers
- Energy efficient lighting - uses (2) 18W (max.) high efficiency, GU24 based, fluorescent bulbs (included) and 4W (max.), type C7 night light bulb (not included)
- Durable steel reflector with white enamel finish

CONTROLS (Purchase separately):

- Refer to NuTone's catalog for a complete line of accessories to effectively adapt these fans to your construction requirements.

U.L. Listed for use over bathtubs and showers when connected to a GFCI protected branch circuit (ceiling mount only).

U.L. Listed for use in insulated ceilings (TYPE I.C.)

3-Year Warranty



QTXEN Series Fan/Light/Night Lights

**MODELS QTXEN080FLT,
QTXEN110FLT**

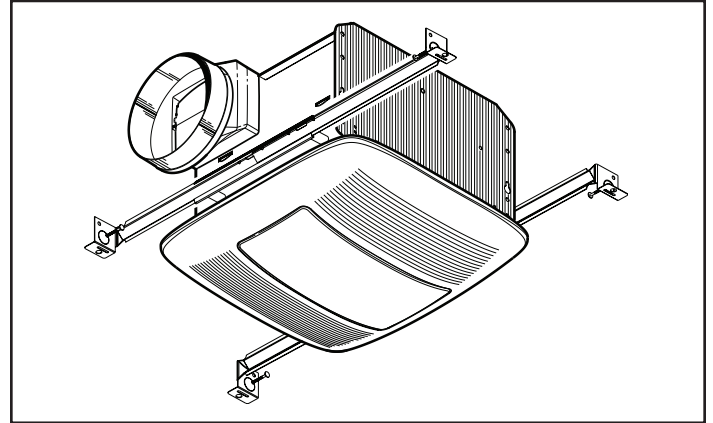

ARCHITECT'S SPECIFICATION

- Fan shall be NuTone Model QTXEN080FLT (QTXEN110FLT).
- Fan shall have corrosion resistant galvanized steel housing with four-point mounting capability. It shall be ducted to a roof or wall cap using 6" round ductwork.
- Blower assembly shall be removable, have a centrifugal-type blower wheel and a permanently lubricated motor designed for continuous operation.
- Non-metallic damper/duct connector shall be included.
- Bulbs shall be (2) 18W (max.) high efficiency, GU24 based fluorescents and separate 4W (max.), type C7 night light bulb.
- Air delivery shall be no less than 80 (110) CFM and sound level no greater than 0.3 (0.7) Sones. All air and sound ratings shall be certified by HVI.
- Fan shall be ENERGY STAR® qualified and have an energy efficient permanent split capacitor motor.
- Fan shall be U.L. Listed for use over bathtubs and showers when connected to a GFCI protected branch circuit (ceiling mount only).
- Fan shall be U.L. Listed for use in insulated ceilings (Type I.C.).

Broan-NuTone LLC Hartford, Wisconsin www.nutone.com 888-336-3948

REFERENCE	QTY.	REMARKS	Project
			Location
			Architect
			Engineer
			Contractor
			Submitted by Date

PERFORMANCE RATINGS

QTXEN SERIES FAN / LIGHT / NIGHT LIGHTS

HVI PERFORMANCE

Model	Static Pressure (Ps)	CFM	Sones	Fan Watts
QTXEN080FLT	0.10	80	0.3	23.3
	0.25	56		
QTXEN110FLT	0.10	110	0.7	31.4
	0.25	86		



HVI-2100 CERTIFIED RATINGS comply with new testing technologies and procedures prescribed by the Home Ventilating Institute, for off-the-shelf products, as they are available to consumers. Product performance is rated at 0.1 in. static pressure, based on tests conducted in a state-of-the-art test laboratory. Sones are a measure of humanly-perceived loudness, based on laboratory measurements.

AMPS

Model	Amps*
QTXEN080FLT	0.8
QTXEN110FLT	1.0

* Total connected load

WEIGHT

Model	Shipping Weight
QTXEN080FLT	16.2 lbs.
QTXEN110FLT	15.8 lbs.

AIR FLOW PERFORMANCE

MODEL QTXEN080FLT

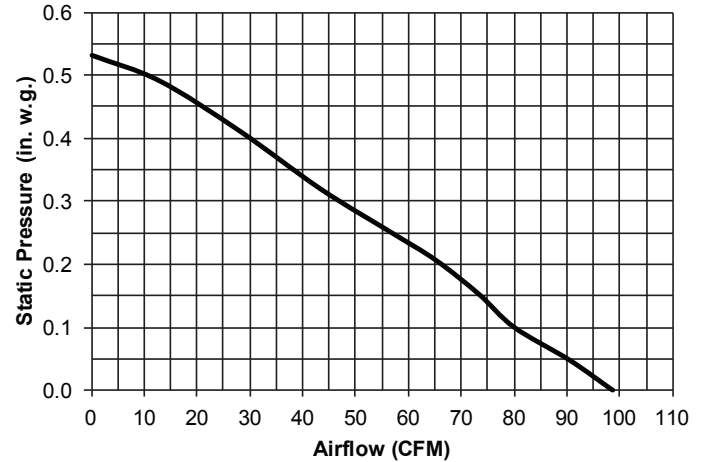

MODEL QTXEN110FLT

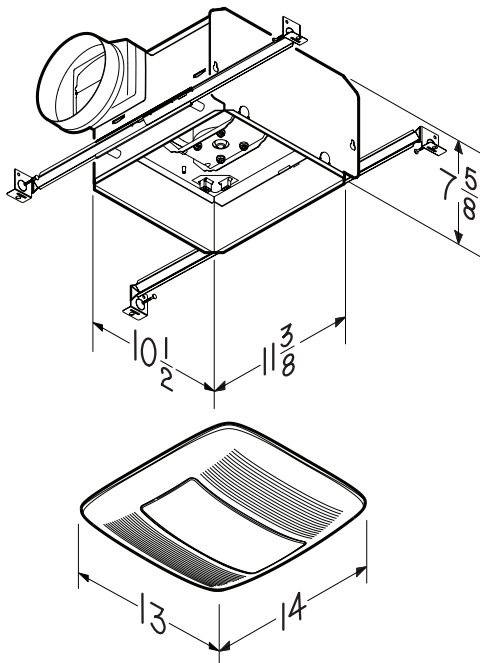
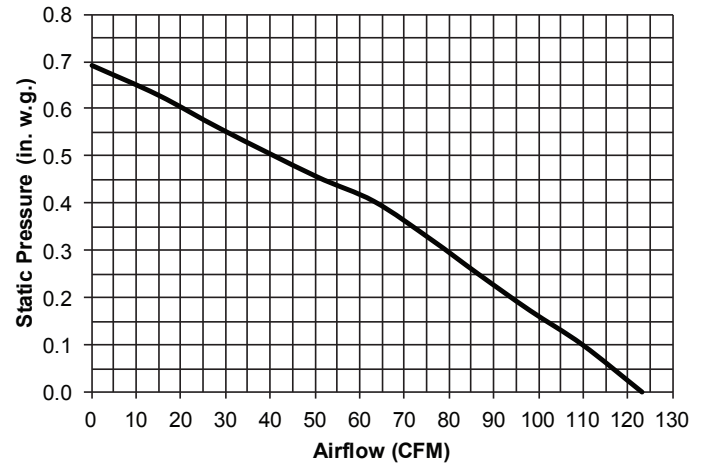

NuTone®

Broan-NuTone LLC Hartford, Wisconsin www.nutone.com 888-336-3948